

TWO OR THREE BUNDLED CONDUCTORS DETACHABLE PULLEYS CST

The pulleys are suitable for stringing two or three bundled conductor lines. The pulleys are made up of a special galvanised steel frame and three single pulleys. The single pulleys can be used separately.

The wheels are made of aluminium alloy mounted on ball bearings; the lateral ones have the groove lined by a neoprene ring; the central one has the groove made up of wear-proof interchangeable nylon sectors. The pulleys are supplied with fixed connection. Grounding device or complete conductive sheaves can be supplied on demand

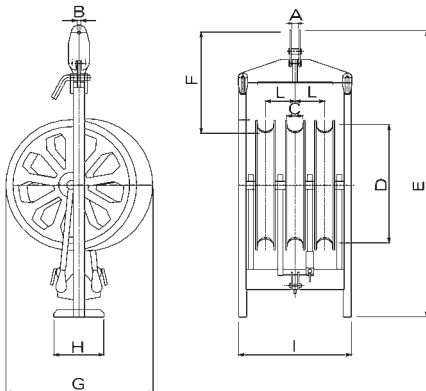

Certified Quality System
ISO 9001:2000

Model	Dimensions [mm]										Breaking load [kN]	Mass [kg]
	A	B	C	D	E	F	G	H	I	L		
CST 500	25	24	68	500	1506	600	699	250	580	148	120	136
CST 600	25	24	68	650	1563	600	846	250	580	148	120	151
CST 601	25	24	95	650	1667	600	846	250	671	178	180	166
CST 800	25	24	68	800	1758	600	951	250	580	148	180	166
CST 801	25	24	95	800	1785	600	964	250	671	178	180	190
CST 001*	25	24	95	1000	1995	600	1171	250	671	178	200	228

* Lateral wheels with nylon lining

FOUR BUNDLED CONDUCTORS DETACHABLE PULLEYS CSQ

The pulleys are suitable for stringing four bundled conductor lines.

The pulleys are made up of a special galvanised steel frame and five single pulleys. The single pulleys can be used separately. The wheels are made of aluminium alloy mounted on ball bearings; the lateral ones have the groove lined by a neoprene ring; the central one has the groove made up of wear-proof interchangeable nylon sectors. The pulleys are supplied with fixed connection. Grounding device or complete conductive sheaves can be supplied on demand

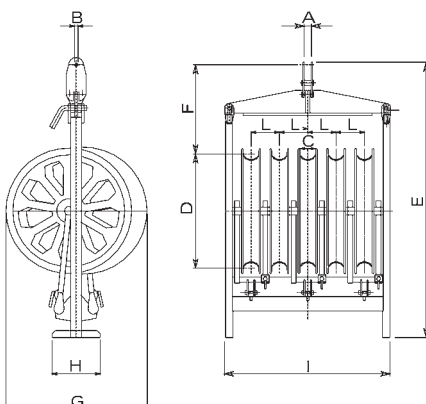

Model	Dimensions [mm]										Breaking load [kN]	Mass [kg]
	A	B	C	D	E	F	G	H	I	L		
CSQ 501	25	24	68	500	1506	600	699	250	880	148	120	212
CSQ 602	25	24	68	650	1653	600	846	250	880	148	120	235
CSQ 603	25	24	95	650	1710	600	846	250	1027	178	180	258
CSQ 802	25	24	68	800	1758	600	951	250	880	148	180	250
CSQ 803	25	24	95	800	1830	600	964	250	1027	178	180	295
CSQ 002*	25	24	95	1000	2036	600	1171	250	1027	178	200	345

* Lateral wheels with nylon lining